

Air Management Inc.

# SLEEVE INSTALLATION INSTRUCTIONS

## BREAKAWAY CONNECTIONS

### Breakaway Style Transverse Joints

• Transverse joints illustrated at right have always been approved as breakaway connections. SMACNA testing has also approved the following variations as breakaway connections.

• Standing "S" joints can be applied with no. 10 sheetmetal screws (through joint and duct) subject to the following limitations: Maximum 2 screws in each side and in bottom joint.

Transverse joints illustrated can be applied as top and bottom joints with Drive Slip - side joints in duct heights up to 20 inches.

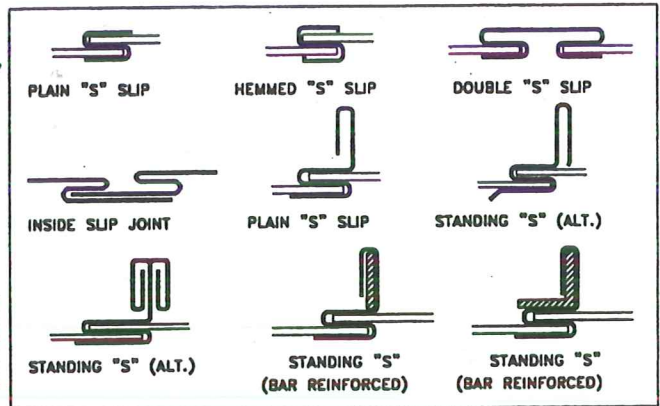
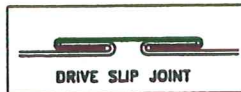

### Round and Oval Duct Breakaway Connections

Round or flat oval ducts connected to type R, CR or CO damper collars may use no. 10 sheetmetal screws as follows: Ducts to 22" wide (or dia.) and smaller may use 3 screws.

Ducts larger than 22" wide (or dia.) may use 5 screws.

NOTE: All breakaway connections described may have duct sealant applied in accordance with SMACNA recommendations.

### Manufactured Flanged System Breakaway Connections

Flanged connection systems manufactured by Ductmate, Ward, and Nexus are approved as breakaway connections when installed as illustrated.

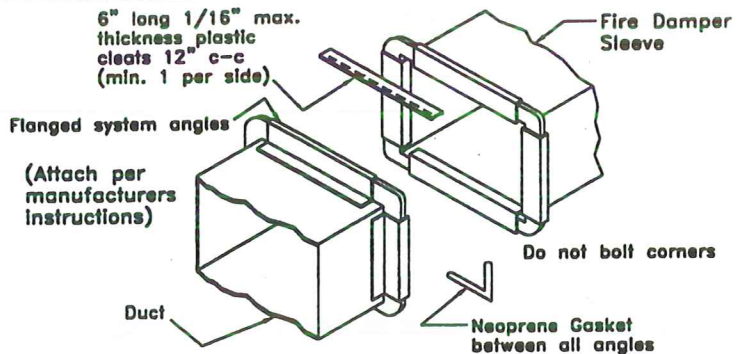

### PROPRIETARY FLANGE SYSTEM BREAKAWAY CONNECTIONS (TDC by Lockformer, TDF by Engle)

TDC and TDF systems are approved as breakaway connections when installed as described in the TDC or TDF addendum to the SMACNA Duct construction Standards except the corners may not be bolted. Standard 6" metal clip may be used with spacing as shown in diagram.

